

QSP

QUALITY STAINLESS PRODUCTS

DB-8000-XL



OPERATING INSTRUCTIONS

This product complies to the ASME standard for Portable Automotive Service Equipment

INSTALLATION INSTRUCTIONS

1. Position the strut compressor in an adequately sized & well-lit area.
2. Level the unit & anchor to the floor according to local building codes using the provided brackets.
3. Connect strut compressor to shop air between 80 & 150psi.
4. Install spring hooks onto the arms of the strut compressor.
5. Store duck feet or any unused hooks in the tool tray on top of the unit.

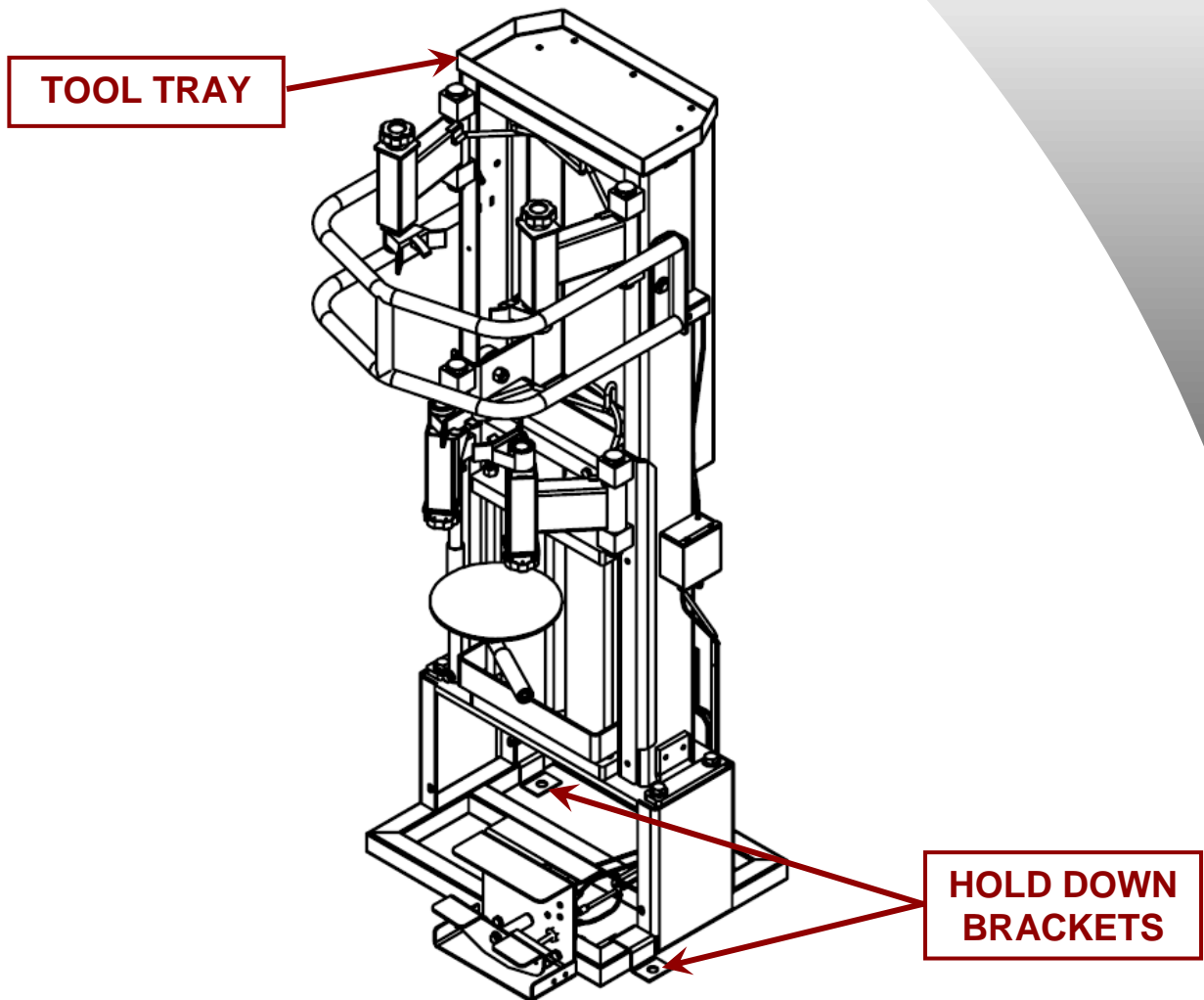

!! CAUTION !!

Before using this device, safety cage must be lowered!



SAFETY INSTRUCTIONS

- ★ Ensure that DB-8000-XL is level and secured to floor.
- ★ Before using the device, cycle the piston to equalize air pressure & avoid an abrupt thrust.
- ★ Be watchful of pinch points on DB-8000-XL & strut assembly; keep extremities out of these areas to avoid injury.
- ★ Prior to starting the compression of any spring, it is imperative to make sure the spring is securely placed between the opposing hooks.
- ★ If a spring begins to deflect or “bow” while under compression, **STOP**, relieve the pressure & reset the clamps closer together.
- ★ Do not place fingers or hands in, on, around, or near moving components while strut compressor is attached to air supply.
- ★ The DB-8000-XL features a safety valve that prevents operation if the safety cage is not lowered.
- ★ Never allow untrained or unauthorized personnel to operate strut compressor.
- ★ Fully train all employees on the proper use and care of your strut compressor.
- ★ One single finger hook and one double finger hook should be used at the top of the unit and also at the bottom.

MAINTENANCE INSTRUCTIONS

To avoid personal injury and damage to strut compressor, permit only qualified personnel to perform maintenance on strut compressor(s). If you are not completely familiar with general automotive equipment maintenance procedures, stop and contact manufacturer for instructions.

DAILY:

- ★ Inspect & repair or replace all loose bolts & damaged or broken components.
- ★ Inspect strut compressor clamp hooks & duck feet for excessive wear or damage & replace as needed.
- ★ Inspect air system for leaks and basic function.
- ★ Inspect retention arms, knobs, foot pedals, and safety cage for damage and wear, replace as needed.

MONTHLY:

- ★ Inspect support tray & spring retention arm assemblies for damage, wear & tear, and dirt and debris in mechanism. Clean, lubricate, repair & replace components as needed.
- ★ Clean strut compressor & inspect for rust.

EVERY 2 YEARS:

- ★ Disassemble air cylinders, inspect seals & lubricate seals with marine grade grease.
- ★ Check all labels on strut compressor for legibility & make sure no labels are missing. Replace as needed.

OPERATING INSTRUCTIONS

Before operating your strut compressor, it is necessary to fully read and understand this instruction packet, & the safety instructions. It is also recommended to dry run the strut compressor before compressing a spring to become familiar with its operation and to help equalize air pressure in the system.

While avoiding any pinch points, follow instructions below to compress a spring:

1. Ensure supply air is connected.
2. Press the foot control pedal to actuate device & equalize air pressure.
3. Lift safety cage & insert strut assembly into the device. Put the low coil of the spring onto the lower left clamp hook.
4. Adjust lower right arm according to the diameter of the spring & turn the adjustment knob until the hook has engaged the coil and the strut assembly is straight up & down.
5. Adjust the upper hooks so that they capture the spring coils at the highest point. This allows for maximum compression.
6. Rotate handle of support plate counter clockwise ensuring that it can move freely. Lift the support plate and rotate it directly beneath the strut assembly and rotate handle clockwise to lock support plate in place.
7. Lower safety cage.
8. While holding the upper arms of the unit in place to support the strut assembly, press the foot control pedal & **SLOWLY** compress the spring until solid contact is made on all hooks.
9. **REMOVE HANDS** from working area inside the safety cage.
10. While standing beside the unit, remove any fasteners from the strut/shock in the assembly. This will allow the strut/shock to rest on the support plate.
11. While supporting the strut/shock, unlock the support plate and move it to the side.
12. Remove old strut/shock and replace with new unit & replace fasteners.
13. Press the foot control pedal to decompress spring and verify that all of the strut assembly components are in the correct orientation and position.
14. Lift the safety cage, disengage spring hooks, and remove strut assembly.



!! WARNING !!

DO NOT disable or override the built in safety measures. Serious injury, property damage, or death may result.

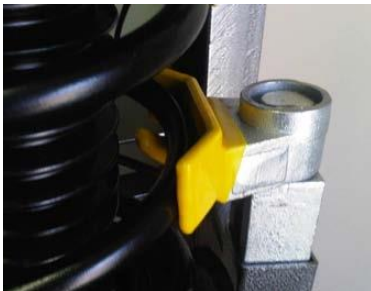

Correct hook engagement on spring coil.



Incorrect engagement.



!! CAUTION !!

DO NOT position any body part directly above or below spring assembly to be compressed!



INSTALLING / USING DUCK FEET

QSP supplies additional accessories to make your strut compressor more flexible. The greater the vertical distance between the upper and lower arms, the easier it is for the unit to compress a spring. On heavier springs, or springs with few coils, using the duck feet instead of the clamp hooks on the upper arms will help to maximize the distance between the arms.

While avoiding any pinch points, follow instructions below to install and use duck feet:

1. Rotate clamp hooks to align key & keyway. Hook or duck foot will now slip off.
2. Reverse sequence to install new clamp or duck foot.
3. Raise the adjustment of the upper arms to their highest position.
4. Insert strut assembly with adapters on top of top hat.
5. Capture at least one stud or install one bolt through the holes of the duck feet.
6. Compress spring as normal making sure that adapters are securely positioned.

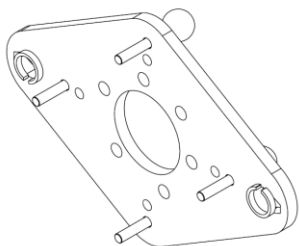

OPTIONAL DIAMOND PLATE ADAPTER

Optional diamond plate adapter kit (PN: 20-8000) is a rigid top plate designed to fit over the top of most strut assemblies, taking the place of hooks or duck feet. The kit contains (1) plate, (2) locking rings & (4) locating pins.

TROUBLESHOOTING

SYMPTOM	PROBLEM	FIX
Arms do not move when foot pedal is pressed. Cylinder starts, but stalls while in motion.	<ol style="list-style-type: none"> 1. Leak in air cylinder 2. Water in cylinder 3. Restricted or kinked air line 4. Leak in air line 5. Insufficient air supply 	Repair / replace cylinder Drain & repair cylinder, replace if needed Locate & correct restriction Locate & repair leak <i>Correct supply (80-150psi, 20-30cfm)</i>
Arms move, but stop before compressing spring.	<ol style="list-style-type: none"> 1. Safety cage not in position 2. Foot valve failure 3. Insufficient air pressure 4. Improper setup 	Ensure cage is all the way down Inspect foot valve & repair/replace if needed Increase pressure, DO NOT exceed 150psi Straighten strut assembly Ensure clamps are place as far apart as possible
Arms drift instead of holding position.	<ol style="list-style-type: none"> 1. Air-line leakage 2. Cylinder leakage 	Find and repair line leak Perform service on cylinder Repair/replace seals
Arms rise in jerking fashion	<ol style="list-style-type: none"> 1. Cylinder issue 	Inspect cylinder seals & repair/replace
Not able to engage clamps on spring	<ol style="list-style-type: none"> 1. Spring doesn't have enough coils 2. Spring length is too short 	Remove upper clamps and replace with duck feet, or optional Diamond plate adapter (PN: 20-8000)

STRUT ASSEMBLY LIMITATIONS

The following parameters outline the most common spring dimensions that the strut compressor will accept.

CYLINDER STROKE (spring compression).....	9 7/8"
FINGER STROKE (clamp adjustment with knob).....	2 5/8"
MAXIMUM DISTANCE BETWEEN UPPER & LOWER CLAMPS.....	12 1/2"
MAXIMUM SPRING DIAMETER.....	Ø11 1/2"
MINIMUM SPRING DIAMETER.....	Ø3 1/2"
MAXIMUM COIL DIAMETER (spring wire).....	Ø1 1/2"
MINIMUM DISTANCE BETWEEN SPRING COILS.....	7/8"

REPLACEMENT PART DIAGRAM & PART NUMBER GUIDE

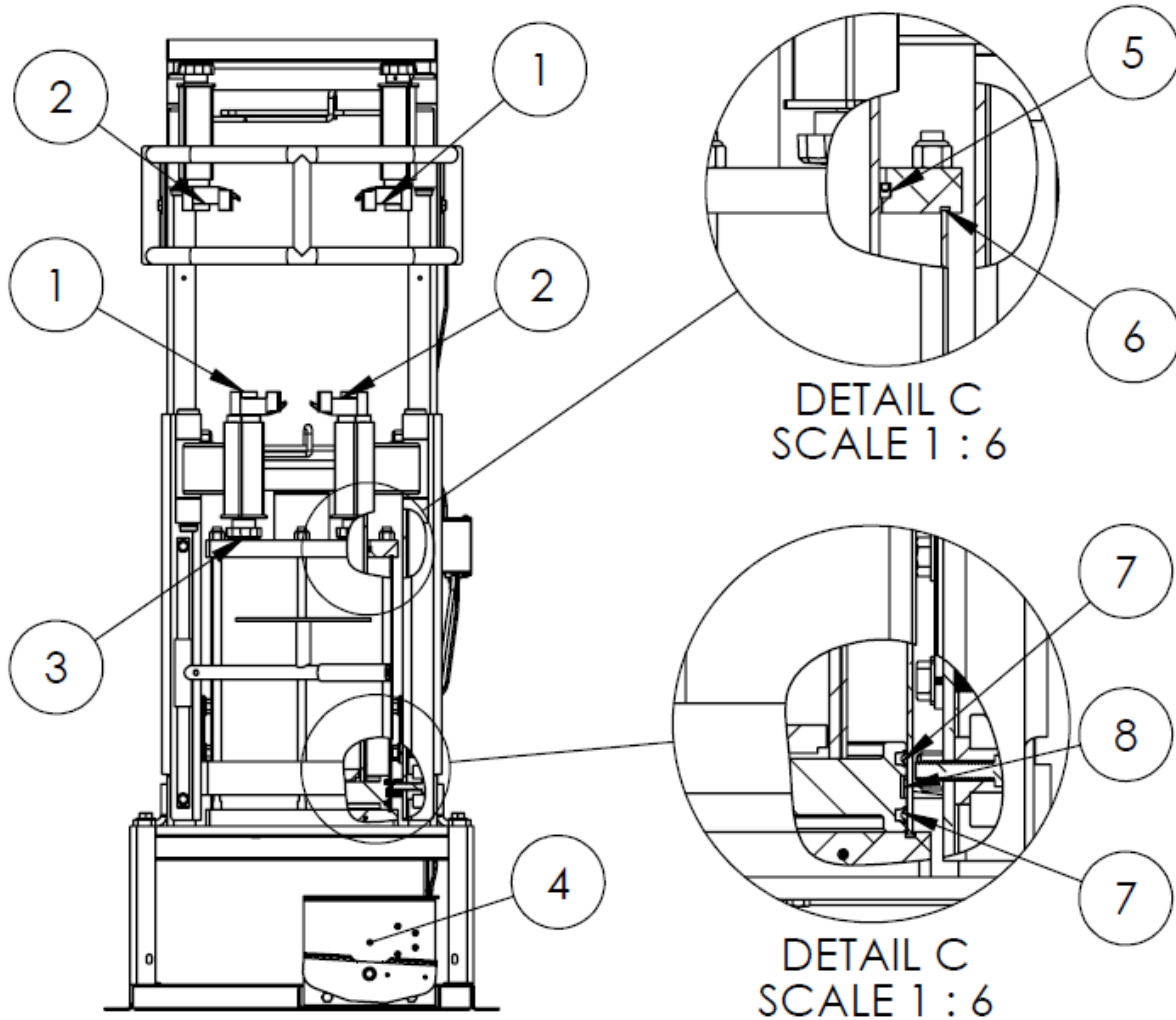

#	PART NUMBER	DESCRIPTION	QTY
1	8000-7	TWO FINGER CLAMP	2
2	8000-13	SINGLE FINGER CLAMP	2
3	DB-8000-070	ADJUSTING KNOB	4
4	DB-7000-359	FOOT VALVE ASSEMBLY	1
5	UCH22502750-312	NITRILE U CUP SEAL	2
6	G-625-J	CYLINDER GASKET	4
7	BV-0450-8BN80	BLOCK VEE WIPER RING	4
8	WR05000X500	WEAR RING	2
9	1030	QUICK DISCON. 1/4 NPT	1

#	PART NUMBER	DESCRIPTION	QTY
10	108-60	CHECK VALVE 1/4 NPT	1
11	1345	1/4 NPT - 3/4-16 THD	1
12	1347	BRASS T - 3X 1/4 NPT	1
13	5779K147	5/32 PUSH X 1/4 NPT ELBOW	5
14	F-1/4 X 1/4NPT L	1/4 TUBE X 1/4 NPT ELBOW	1
15	T-.156X16 K-NYL TUBE	5/32 OD NYLON TUBE - BLK	3FT
16	T-.250 PU BLACK TUBE	1/4 PLASTIC AIR LINE - BLK	3FT
17	5779K32	5/32 UNION TEE	3
18	8000-6	DUCK FEET	2

PNEUMATIC SCHEMATIC

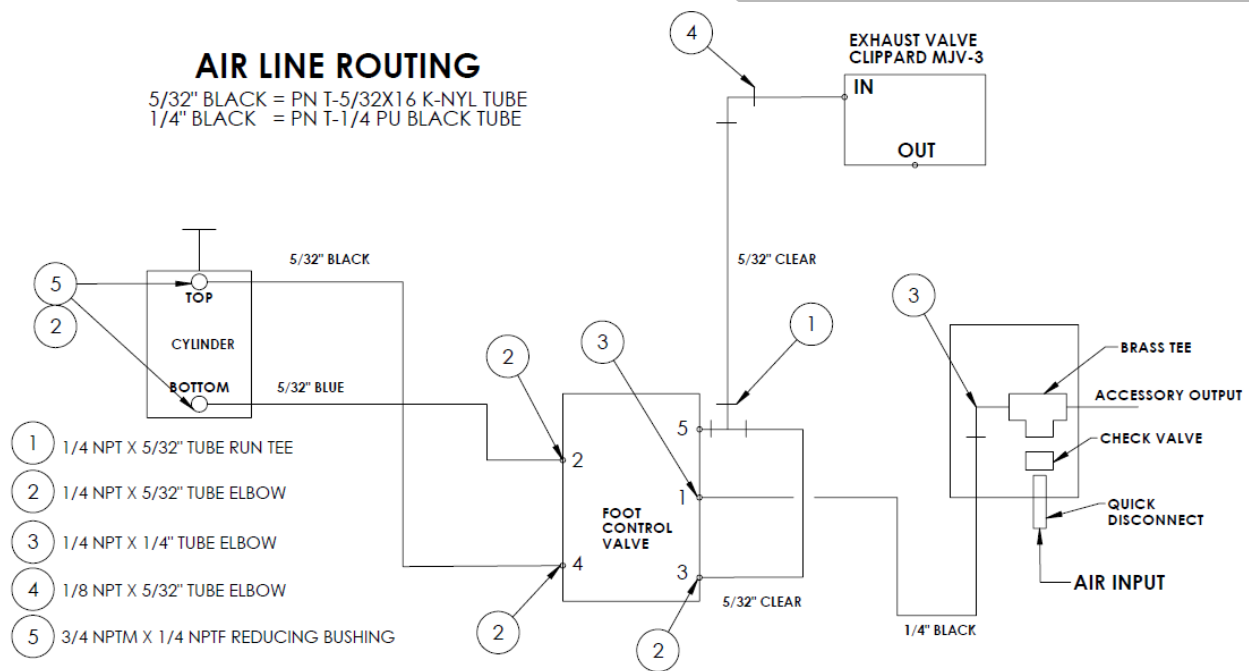

WARRANTY INFORMATION

Your DB-8000-XL Strut Compressor has been thoroughly tested and is guaranteed for a period of 12 months from the date of delivery. Under the terms of this guarantee, all components which are proven to be defective within the warranty period will be repaired or replaced free of charge. Our technical service assistance is the sole authority in determining whether or not defects come under the coverage of the guarantee. The guarantee excludes all responsibility on the part of Quality Stainless Products (QSP) for direct or indirect loss or damage to persons or things deriving from incorrect operation or servicing of this product. This guarantee is limited to defects in materials, workmanship and assembly, and excludes all components subject to normal wear. Furthermore, the guarantee excludes return shipping of defective part(s) to QSP. QSP will however ship the replacement part by standard ground service at no charge.

QSP will not assume liability for damages caused by improper use of the strut compressor including using the device for something other than its intended use.

Parts Department 888-473-5378
TYPE: Strut Compressor
MODEL: DB-8000-XL

Serial Number:

Please retain this document for reference when calling Technical Assistance.